



Basic Electronics For Ceramic Engineers

By: James A. Harrington
Professor of Ceramic Science
Rutgers University, Piscataway, NJ

Purpose:

This is a two part laboratory which will introduce you to some of the basic concepts of laboratory instruments and some simple circuits. The objective of this laboratory is for you to become familiar with some common electronic instrumentation which you will encounter in your laboratory work. There are four pieces of equipment which you will use: an oscilloscope, a digital multimeter (DMM), a DC power supply, and a function generator. The basic idea is to learn how these instruments work and how to use them to measure some simple circuit properties. Included in the appendices of this write-up are some instructions on the use of these instruments. In general, the pages for the operating manuals will be sufficient to get you started but you will have to just experiment with the controls yourself to get a true feeling of how the instruments work.

This experiment covers two weeks of laboratory work. You are required to write only one laboratory report which will cover those two weeks of work. The first part of the work will introduce you to some simple circuit components like resistors and capacitors and how to use some of the instruments. In this part of the laboratory you will work with DC measurements and circuits. In the second part you will do AC measurements which will involve some of the same circuits but using the function generator instead of the DC power supply. *Note:* Some of the material on the working of the oscilloscope is taken from J.P. Holman, *Experimental Methods for Engineers*, McGraw-Hill, New York, 1989.

Note: The following paragraphs describe the analog oscilloscope. Most new oscilloscopes today are digital, not analog, and offer substantial benefits over the analog scope. Hewlett-Packard stopped introducing analog scopes over 20 years ago, but we are including this experiment set for completeness.

The Cathode-ray Oscilloscope (CRO)

This is one of the most versatile pieces of laboratory test equipment that you will use. It is really a type of analog voltmeter with an arbitrary zero. It can read DC voltages as an offset voltage and as well as AC voltages by displaying the true wave form. Most modern oscilloscopes are capable of measuring AC signals over a wide range of frequencies and you should check your oscilloscope for its frequency response.

The heart of any oscilloscope is the cathode-ray tube (CRT), which is shown schematically in Fig. 1. Electrons are released from the hot cathode and accelerated toward the screen by the use of a positively charged anode. An appropriate grid arrangement then governs the focus of the electron beam on the screen. The exact position of the spot on the screen is controlled by the use of the horizontal and vertical deflection plates. A voltage applied on one set of plates produces the x deflection, while a voltage on the other set produces the y deflection. Thus, with appropriate voltages on the two sets of plates, the electron beam may be made to fall on any particular spot on the screen of the tube.



The screen is coated with a phosphorescent material, which emits light when struck by the electron beam. If the deflection of the beam against a known voltage input is calibrated, the oscilloscope may serve as a voltmeter. Since voltages of the order of several hundred volts are usually required to produce beam deflections across the entire diameter of the screen, the cathode-ray tube is not directly applicable for many low-level voltage measurements, and amplification must be provided to bring the input signal up to the operating conditions for the CRT.

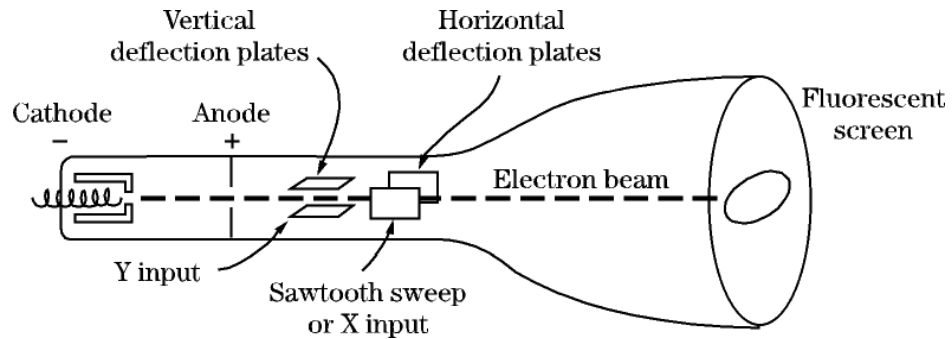

Figure 1 - Schematic diagram of cathode-ray tube (CRT)

A schematic of the oscilloscope is shown in Fig. 2. The main features are the CRT, as described above, the horizontal and vertical amplifiers, and the sweep and synchronization circuits. The sweep generator produces a sawtooth wave which may be used to provide a periodic horizontal deflection of the electron beam, in accordance with some desired frequency. This sweep then provides a time base for transient voltage measurements by means of the vertical deflection. Oscilloscopes provide internal circuits to vary the horizontal sweep frequency over a rather wide range as well as external connections for introducing other sweep frequencies. Internal switching is also provided, which enables the operator of the scope to “lock” the sweep frequency onto the frequency impressed on the vertical input. Provisions are also made for external modulation of the intensity of the electron beam. This is sometimes called the z-axis input. This modulation may be used to cause the trace to appear on the screen during certain portions of a wave form and disappear during other portions. It may also be used to produce traces of a specified time duration on the screen of the CRT so that a time base is obtained along with the wave form under study.

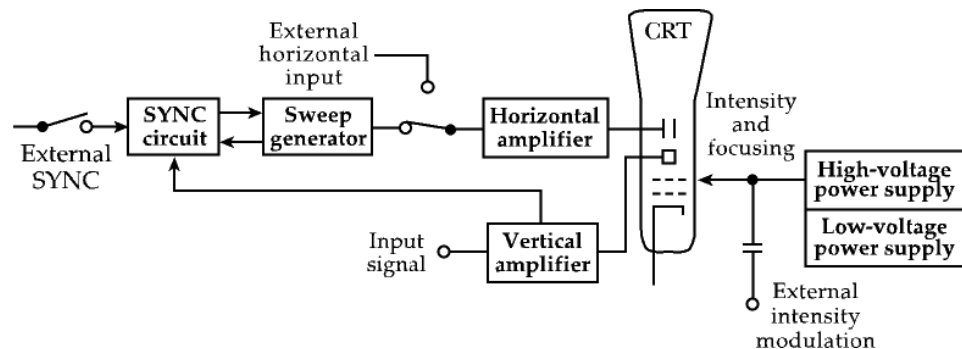

Figure 2 - Block schematic diagram of an oscilloscope

A dual-beam oscilloscope provides for amplification and display of two signals at the same time, thereby permitting direct comparison of the signals on the CRT screen. A single-beam oscilloscope may be given a dual-beam function through the use of an electronic switch which



is most commonly incorporated in the oscilloscope itself. This device switches between two inputs and alternately impresses the two signals into the single-beam oscilloscope. You will thus see both signals simultaneously. In fact, each signal is displayed in turn at a very fast rate so that it appears as if both are on all the time. The advantage is that you can compare two or sometime even more signals without having to switch your input signal manually.

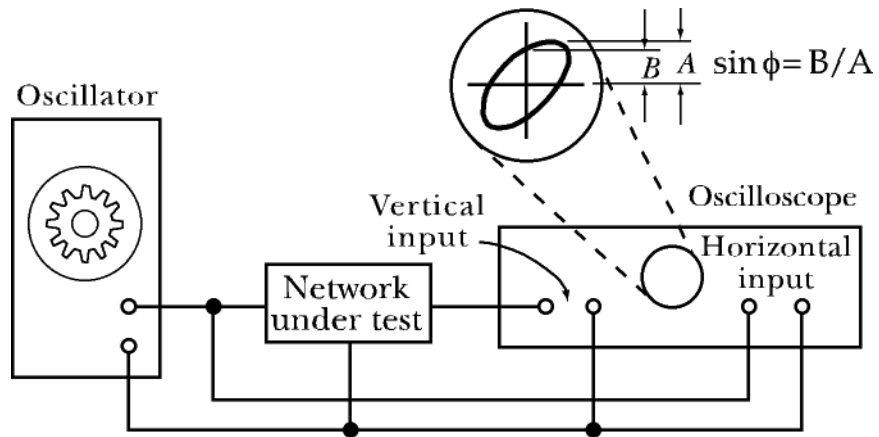

Figure 3 - Use of oscilloscope for phase measurements

The CRO may be used to measure phase shift in an electronic circuit, as shown in Fig. 3. An oscillator is connected to the input of the circuit under test. The output of the circuit is connected to the CRO vertical input, whereas the oscillator signal is connected directly to the horizontal input. The phase-shift angle ϕ may be determined from the relation,

$$\phi = \sin^{-1} \frac{B}{A}$$

where B and A are measured as shown in the figure. For zero phase shift the ellipse will become a straight line with a slope of 45° to the right; for 90° phase shift it will become a circle; and for the 180° phase shift it will become a straight line with a slope of 45° to the left.

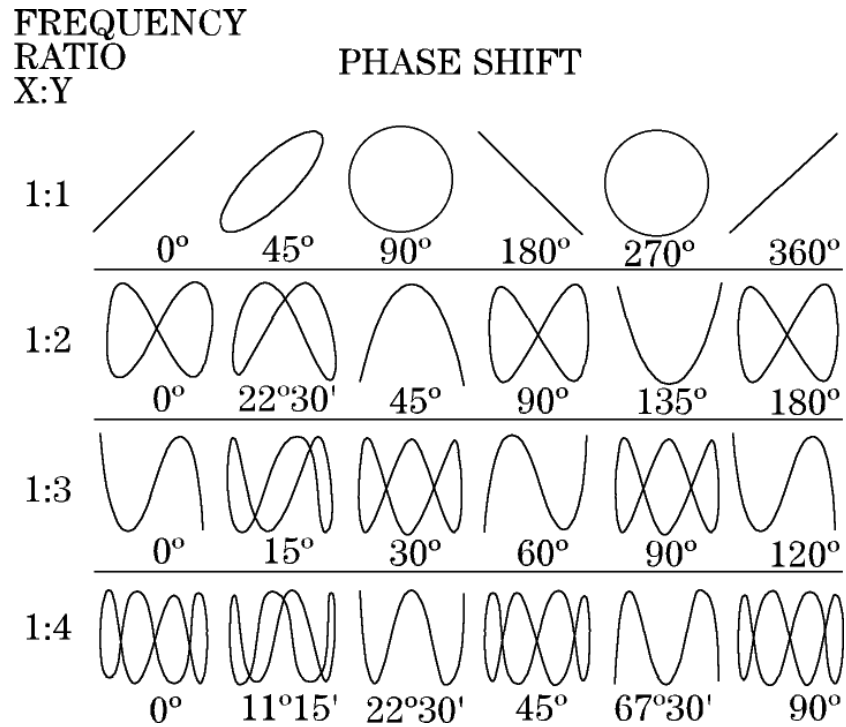

Figure 4 - Lissajous figures for different phases.

The CRO offers a convenient means of comparing signal frequencies through the use of Lissajous diagrams. Two frequencies are impressed on the CRO inputs, one on the horizontal input and one on the vertical input. One of these frequencies may be a known frequency as obtained from a variable frequency oscillator or signal generator. If the two input frequencies are multiples of each other then the patterns that are displayed on the CRT screen are called Lissajous diagrams. The frequency ratio is related to number of vertical and horizontal maxima of the diagrams.

Some typical shapes for the Lissajous diagrams are shown in Fig. 4. It may be noted that these shapes can vary somewhat depending on the phase relation between the input signals. Oscilloscope traces may be recorded by various photographic methods, and several cameras are manufactured especially for oscilloscope applications.

The Function Generator

This device produces sine, square, and triangle waves plus a few others that you will not need. The frequency range is from less than 1 Hz to many MHz. You will use this generator to provide an AC signal to your circuits and the oscilloscope. This will enable you to study different wave forms and to get an understanding of some basic AC signals. Initially you will make some measurements of voltage and current using the DC power supply and a simple circuit. Then you will substitute the DC source with the function generator.

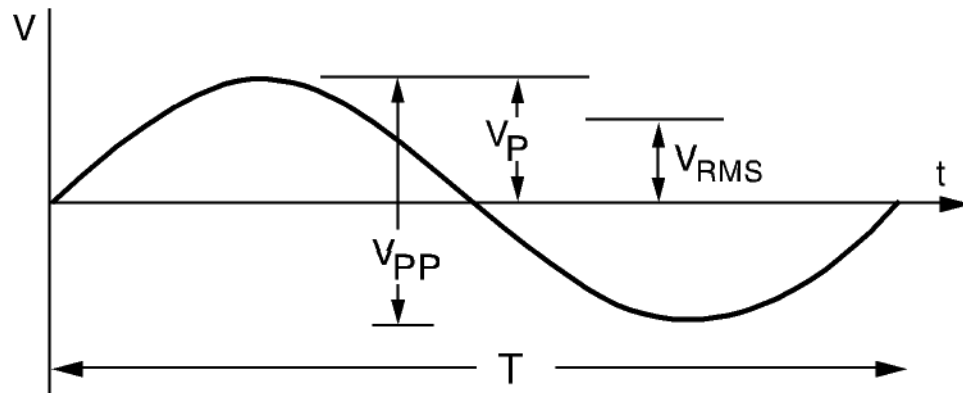

Figure 5 - Measurement of voltages on an oscilloscope

The simplest AC signal is the sine wave and you should use this function as your first AC source. When this signal is connected to the oscilloscope, you can see that you can easily measure the peak AC voltage, V_p , which is defined as the voltage measured from the center or zero position to the peak (see Fig. 5). There are several other voltages that can also be measured. The peak-to-peak voltage, V_{pp} , is the voltage measured from the crest of one cycle to the bottom trough of the cycle or peak-to-peak. Finally, the most common voltage is the rms or root-mean-square voltage, V_{rms} . It is equal to the peak-to-peak value divided by (2×1.414) . For the sine wave only:

$$V_p = V_{pp} / 2 = \sqrt{2} V_{rms}$$

A one volt rms waveform has the same heating value as a one volt dc signal.

DC Power Supply

This instrument is really nothing more than a fancy battery. It provides a variable voltage and current which is convenient for powering test circuits and for quickly making up a test circuit. Many times it is necessary to have an alternative power source when you breadboard a circuit and this instrument is very handy. While this all seems simple and straight forward, good DC power supplies are not cheap because the DC voltage and current must have minimal noise. That is, the signal should be well filtered of AC noise and the DC signal should be quite stable. This is especially important for modern circuitry where noise and instabilities can adversely impact our solid state microelectronics.

Digital Multimeter (DMM)

This is a very versatile piece of test equipment which is essential in every laboratory. It is a marvel of modern electronics in the it can be used to measure many functions. These include the usual voltage, current, and resistance as well as capacitance, diode testing, and circuit continuity. These instruments have a very high input impedance so that they are virtually not seen by the circuit under test. That is, they do not impose any significant load on the circuit. You will find that this instrument is very handy doing mundane jobs like determining if a circuit is continuous to more sophisticated chores such as component testing. You will use the DMM



to measure voltage and current and to compare the values that you get to some you take using the oscilloscope.

RC Circuits

Capacitors are very important components in electronic circuits and they are of special interest to us because they are frequently made from ceramic materials. One way to look at a capacitor is that it is a frequency dependent resistor which can be used in AC circuits as a filter or a bypass component. Yet it is different than a resistor because it stores charge in an amount of Q coulombs. By definition, $Q = CV$, where C is the capacitance in farads. A farad is an extremely large unit so typical capacitors have values in the microfarad, μF (10^{-6} F), or picofarad, pF (10^{-12} F), range. Taking the derivative of the defining equation with respect to time gives,

$$\frac{dQ}{dt} = i = C \frac{dV}{dt}$$

We see from this relationship that a capacitor is more complicated than a resistor in that the current is not proportional to V but rather to the rate of change of voltage. For example if you apply a current of 1 ma to a 1 μF capacitor, the voltage will rise at 1000 V/sec. Most current sources and most capacitors that you will encounter, however, are not designed to generate or store thousands of volts. A resistor network can be used to limit the voltage buildup across the capacitor.

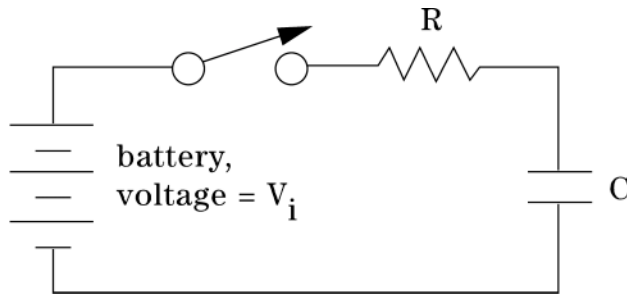

Figure 6 - Simple RC circuit.

One of the most important types of circuit containing capacitors is the RC circuit. Consider the simple circuit shown in Fig. 6. The equation for this circuit with current i, voltage V across the capacitor, and source voltage V_i is,

$$V_i = Q/C + iR = V + R \frac{dQ}{dt}$$

This is a first order differential equation which we can easily solve using the boundary condition that at $t = 0$ when the switch is thrown, the voltage across the capacitor, $V = Q/C = 0$. The solution for V is

$$V = V_i (1 - e^{-t/RC})$$

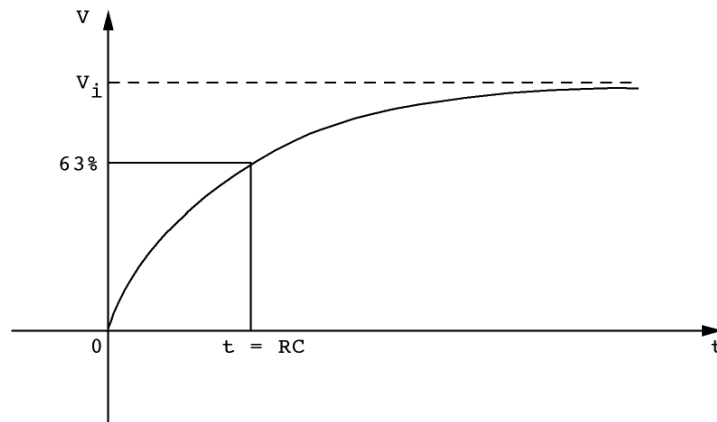

Figure 7 - Charging voltage for a capacitor.

The product RC is called the time constant with units of seconds if C is in farads and R is in ohms. Therefore, when the switch is thrown, the capacitor charges exponentially and the voltage V approaches V_i asymptotically. This is shown in Fig. 7. When $t = RC$ then the voltage across the capacitor, V , is 63% of V_i . As a rule of thumb, V is approximately equal to V_i when $t = 5RC$. In this experiment you will make a RC circuit and measure the time constant. Hopefully your data will look like the curve in Fig. 7!

Experiment: Part 1

1. Resistors in series:

Set-up the simple circuit using two different resistors from the parts box. Measure the resistance for each resistor separately using the DMM. What is the value of each resistor and how does this compare with the value indicated by the color code on the resistor? Does your value fall within the tolerance range as indicated on the resistor? Now measure the total series resistance, $R_1 + R_2$. What is the relationship for total resistance of n resistors?



2. Resistors in parallel:

Set-up the simple circuit below for two different resistors in parallel. Measure the resistance of the combination using the DMM. What is the relationship for the total resistance of this pair of parallel resistors? Give a relationship for the total resistance of n parallel resistors. If both resistors have the same value, R , give a simple formula for the total resistance for the two resistors.

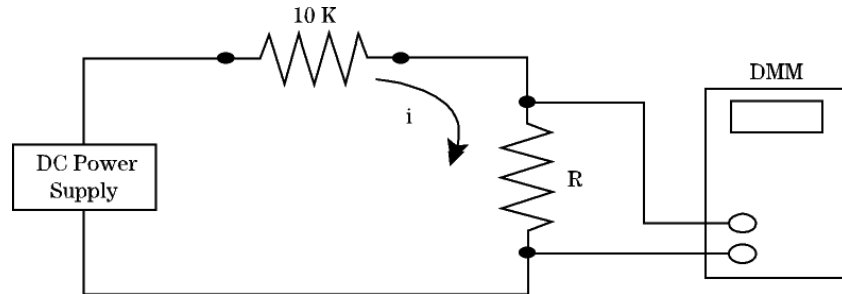
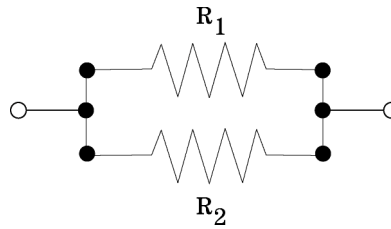

Figure 8 - Simple DC circuit.

3. Simple DC circuit:

Set up the circuit shown in Figure 8 above. Use the DC power supply as the source. First measure and record the voltage across an unknown resistor R using the DMM as a voltmeter. Next measure the current flowing in the circuit by disconnecting one end of the resistor and using the DMM as a current meter in series with the resistor. Measure the current using two current scales. Is there a difference in the current reading? Vary the voltage in the circuit and repeat the measurement. Calculate the value of R from your current and voltage readings. Compare this value to what you measure using the DMM to measure resistance. Do you need to remove the resistor from the circuit to measure its true resistance? This is important and you should compare the value you get measuring the resistance in the circuit (**be careful**: turn off the power before measuring any resistance) versus the value measured on the isolated component. Does the presence of the DMM alter the value of i and R ? Using the internal resistance of the DMM given by the manufacturer, calculate the effect of the DMM on the value of R that you measure when R is measured directly, i.e. R is out of the circuit.

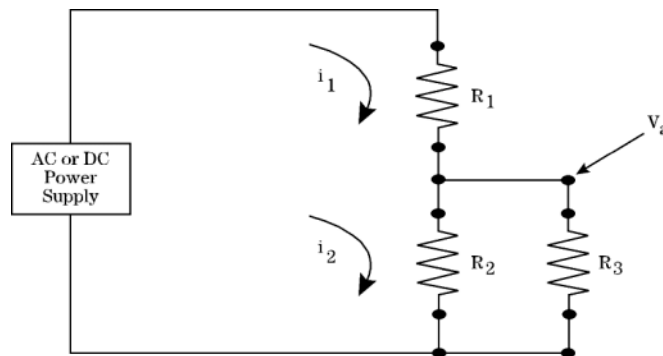
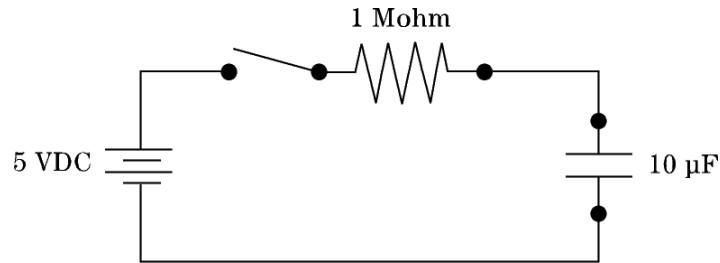

Figure 9 - Complex circuit for measurement of R , i , and V using either a DC or AC source.

4. Complex circuit measurements: Set up the more complex circuit shown in Figure 9 above. Measure the voltages and currents indicated. Be sure to note the direction of



the current flow. Again, calculate the value of R_1 , R_2 , R_3 and compare this to a direct measurement of the resistance. Make a table of the values that you measure and calculate. Verify Kirchhoff's laws for your circuit. Kirchhoff's laws state that the instantaneous sum of the voltages around any loop is zero or $(\sum)V = 0$ (voltage law) and that the instantaneous sum of currents at a node is zero or $(\sum)i = 0$ (current law). Verify these laws for your circuit by specifically demonstrating the voltage law for the left loop (source, R_1 , and R_2) and the current law for the node at V_a .



5. Time constant of an RC circuit: In this part of the experiment you will set-up a simple RC circuit so that you can charge a capacitor and measure its time constant RC. Set-up the circuit shown using a 1 M ohm resistor and a 10 µF capacitor. What is the time constant for this circuit based on these values of R and C? This will give you an idea of what to expect when you measure the voltage building up across the capacitor, i.e. the charging voltage.

With the DMM across the capacitor connect the power supply to resistor. This will start the charging cycle. Using a stop watch to measure the capacitor voltage as a function of time for times 6 to 7 times the time constant.

Plot the data for charging voltage versus the time. This should give you a graph similar to that shown in Figure 7. From the graph determine the time constant and compare this result to the calculated value. Why is there a difference?

Leaving the DMM attached, disconnect the wire from the power supply and move it across to the capacitor thereby shorting the capacitor though the resistor, i.e. no power supply in the circuit. Now measure the discharging voltage and time as the capacitor discharges to zero volts. Plot this data on the same graph as the charging voltage and compare your results. Is it true that after 5RC the capacitor is essentially charged or discharged? Shorting out large capacitors is always important after a circuit is turned off if you intend to work on the circuit. This is a good safety practice.

The solution for the voltage across the capacitor was given as,

$$V = V_i (1 - e^{-t/RC})$$

Taking the natural logarithm of both sides and rearranging we have the relationship,

$$\ln \left(\frac{V}{V_i} \right) = \frac{t}{RC}$$

Treating the logarithm as one variable and t as a second, this is an equation of a straight line with an intercept of zero and a slope of 1/RC. Plot the logarithm versus t and from the slope obtain the value of RC.



6. Extra credit: If time permits, use the oscilloscope in the DC mode in place of the DMM to observe the charging of the capacitor. Using this very versatile instrument you can “see” the charging and discharging and even measure the time constant directly off the screen if things are calibrated correctly. Compare your results with those using the DMM.

Experiment: Part 2

In this part of the experiment you will use the function generator to supply AC signals to the various circuit components.

1. Simple AC circuit:
Using the circuit shown in Fig. 9, replace the DC supply with the function generator. Use a frequency of 1 kHz and a sine wave function. Repeat the measurement of current, resistance, and voltage using the DMM and the oscilloscope. Make a table comparing these values for the two instruments. What AC voltage does the DMM read? Measure V_{pp} , V_p , and V_{rms} using the oscilloscope. How does the value of V_{rms} measured with the oscilloscope compare to the voltage measured with the DMM?
2. Frequency and pulse width measurements:
In this part of the experiment you will use the function generator directly as a source for the oscilloscope. Connect the function generator to the vertical input of the scope and use the time base to reproduce the sine or square waves generated by the source. Use three different frequencies, 1 kHz, 10 kHz and 1 MHz, and both the sine and square wave functions. Sketch what you see on the screen and indicate under each sketch the settings for the scope and the generator. This is critical because you want quantitative information from these traces. Normally, the scope output would be recorded either directly on film or, for a digital scope, passed directly to a computer. Your sketch is a simple way of recording the trace. Measure the frequency of each signal from the oscilloscope trace and compare this value to that indicated on the function generator. Next, study the square wave output on the scope. Measure the rise time for each of the frequencies. This is the time it takes the square wave to rise from one level to another. See the instructions for the scope in the appendix. Vary the duty cycle (dead time) of the square wave using the control on the function generator. From the scope trace, verify that the duty cycle is indeed varied and sketch several examples of different duty cycles.

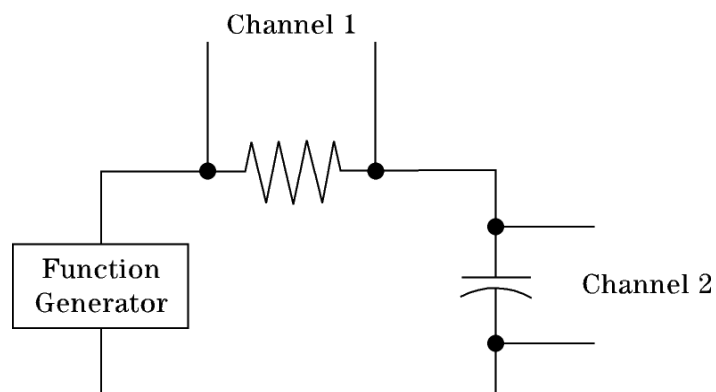



- Note:* The above measurement calls for the use of two separate grounds for the oscilloscope. This can be accomplished one of three ways:
- 1) Use a scope with floating differential inputs.
 - 2) Use a scope with a differential probe.
 - 3) Use a math function on the scope. With CH1 connected across the function generator and CH2 connected across the capacitor, the [CH1-CH2] math function gives the voltage across the resistor.

3. Frequency and phase measurements:

In this part of the experiment you will use two methods to make frequency and phase difference measurements. The first method uses the scope's dual trace capability to measure the phase difference and the second treats the scope as an X-Y scope. A simple method to observe a signal which is shifted in phase from another is to use a RC circuit. You have seen that a capacitor has an unusual voltage charging effect. This is a result of the voltage across the capacitor "bucking" the input voltage with the result that the capacitor takes time to charge. For an AC signal, this translates into a phase shift of the signal through a capacitor compared to that through a resistor. Therefore, by comparing a signal across the resistor and a signal across the capacitor in an RC circuit we can see the phase difference. Set-up the simple RC circuit shown below using the function generator to deliver a sine wave of 1 kHz. The oscilloscope is to be connected so that one channel measures the voltage across the resistor and the other channel measures the voltage across the capacitor.

The first method uses the dual channel capability of the scope to compare the two signals and thus to determine the phase shift. You should observe the dual trace for these sine waves and then be able to measure the phase difference between the two signals by measuring the time delay between the leading and lagging peaks of the two signals. Repeat the experiment using 100 kHz. What happens to the phases of the two signals?

The second method uses the concept of the Lissajous figure to measure the phase shift. Apply one signal to the horizontal input and the other to the vertical input. You should see a circle if the two frequencies are equal and the phase delay is zero. As noted in the introduction, the circle will be canted if the phase on the two sine waves is different. You should measure A and B and use these to calculate the phase shift. Compare the results with the measurement using the dual trace method. Which method is more reliable?

4. Lissajous figures:

You should apply two frequencies to the X and Y channels of the oscilloscope. One of the frequencies should be from the function generator and the other from the transformer which will give you a fixed 60 Hz signal. Arrange the generator frequency so that you have multiples of the 60 Hz signal and thus you will have different Lissajous figures. Sketch the figures for three frequencies.